

**Trasmittitori**  
**Transmitters**  
**Emisores**  
**Télécommandes**  
**Senders**



Strumento di lavoro

**VISIO**, il trasmettitore multicanale con display grafico

Fingertip instruments

**VISIO**, the multichannel transmitter with a graphic display



# Kort

**MINI TRASMETTITORE 1 CANALE**  
**1 CHANNEL MINI TRANSMITTER**  
**MINI EMISOR 1 CANAL**  
**TÉLÉCOMMANDE MINI 1 CANAL**  
**MINI-FUNKSENDER 1 KANAL**

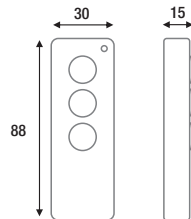
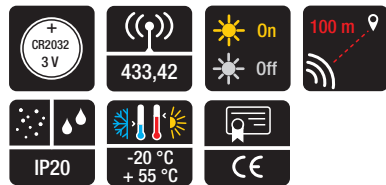

# Arco

**TRASMETTITORE DA 1 - 2 - 5 - 10 E 20 CANALI**  
**1 - 2 - 5 - 10 & 20 CHANNEL TRANSMITTER**  
**EMISOR 1 - 2 - 5 - 10 Y 20 CANALES**  
**TÉLÉCOMMANDE 1 - 2 - 5 - 10 ET 20 CANAUX**  
**FUNKSENDER 1 - 2 - 5 - 10 UND 20 KANÄLE**

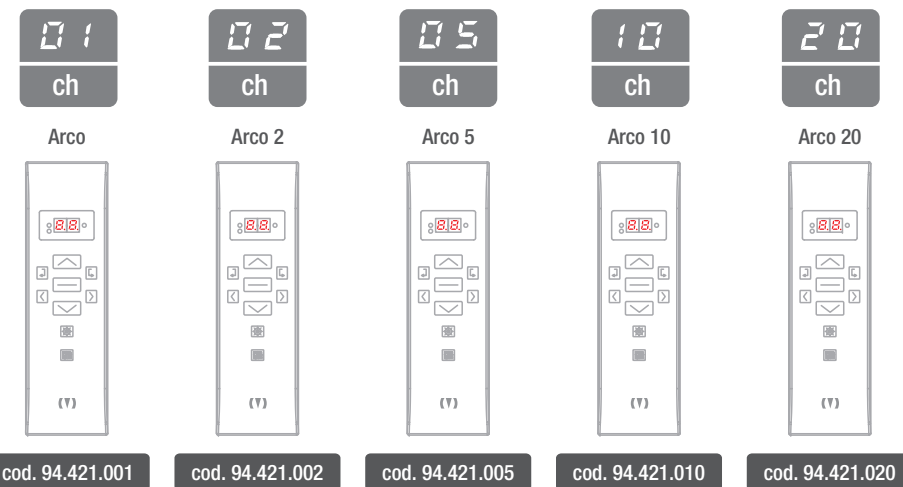
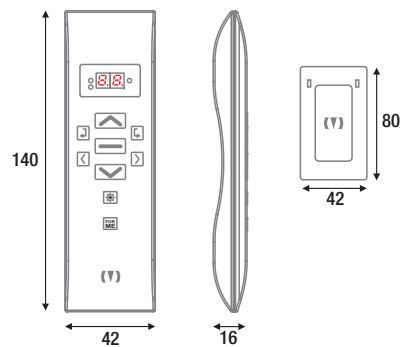
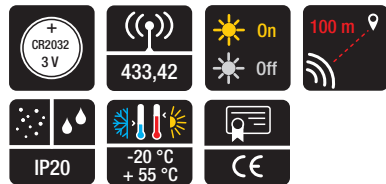

Quote espressa in "mm" - Dimensions expressed in "mm" - Medidas expresadas en "mm" - Dimensions exprimées en "mm" - Maße ausgedrückt in "mm"

# Kuadro

**TRASMETTITORE DA PARETE 1 CANALE**  
**1 CHANNEL WALL TRANSMITTER**  
**EMISOR DE PARED 1 CANAL**  
**TÉLÉCOMMANDE MURALE 1 CANAL**  
**WAND-FUNKSENDER 1 KANAL**

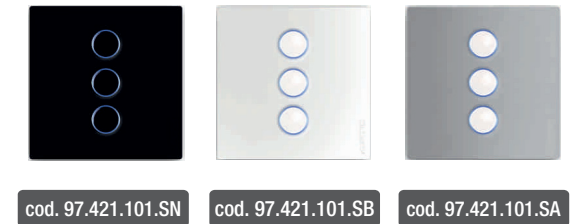
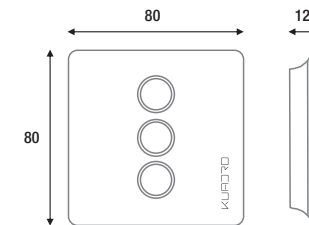
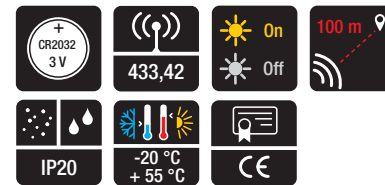

# Flute

**TRASMETTITORE DI DESIGN DA 1 E 5 CANALI**  
**1 OR 5 CHANNEL DESIGN TRANSMITTER**  
**EMISOR DE DISEÑO 1 OU 5 CANALES**  
**TÉLÉCOMMANDE DESIGN 1 OU 5 CANAUX**  
**DESIGN-FUNKSENDER 1 UND 5 KANÄLE**

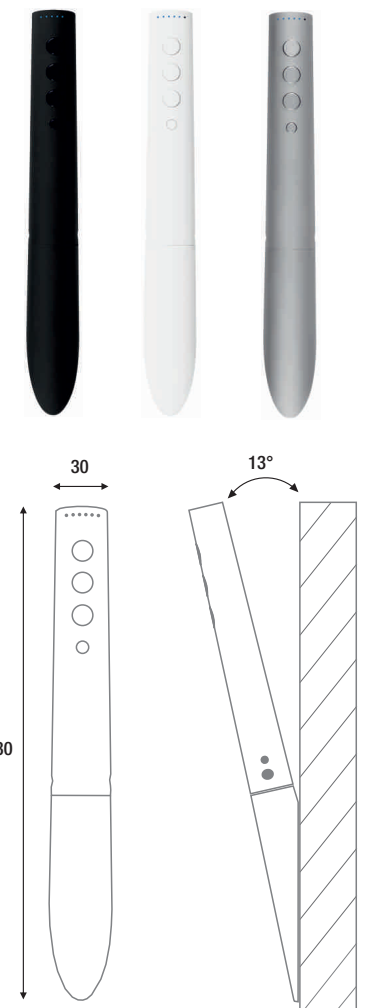
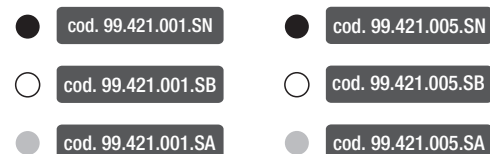
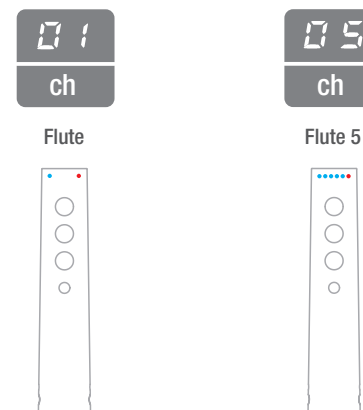
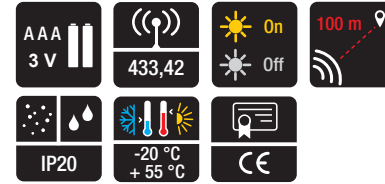

Quote espressa in "mm" - Dimensions expressed in "mm" - Medidas expresadas en "mm" - Dimensions exprimées en "mm" - Maße ausgedrückt in "mm"

# Visio

cod. 96.421.020

**5 YEAR WARRANTY**

**TRASMETTITORE 20 CANALI CON DISPLAY GRAFICO (5 LINGUE)**  
**20 CHANNEL TRANSMITTER WITH GRAPHIC DISPLAY (5 LANGUAGES)**  
**EMISOR 20 CANALES CON PANTALLA GRAFICA (5 IDIOMAS)**  
**TÉLÉCOMMANDE 20 CANAUX AVEC ÉCRAN GRAPHIQUE (5 LANGUES)**  
**FUNKSENDER 20 KANÄLE MIT GRAFIK-DISPLAY (5 SPRACHEN)**

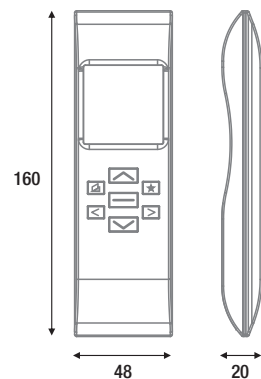
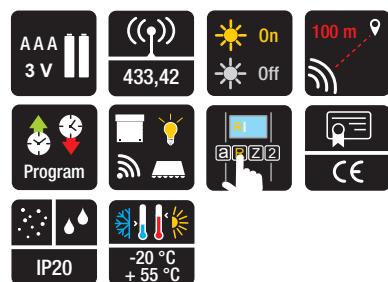

# Mir DCT

cod. 92.421.018

**5 YEAR WARRANTY**

**TRASMETTITORE 1 CANALE A TENSIONE DI RETE CON CONTATTI DI INGRESSO PULITI**  
**1 CHANNEL TRANSMITTER POWERED BY MAIN VOLTAGE WITH DRY CONTACT INPUTS**  
**MANDO ELÉCTRICO 1 CANAL CON ENTRADAS DE CONTACTO SECO**  
**TÉLÉCOMMANDE ÉLECTRIQUE 1 CANAL AVEC ENTRÉES CONTACTS SECS**  
**FUNKSENDERMODUL 1 KANAL, MIT NETZSPANNUNGSVERSORGUNG UND MIT POTENTIALFREIEN KONTAKTEN IM EINGANG**

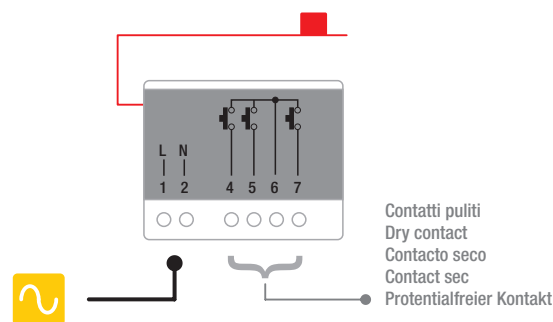
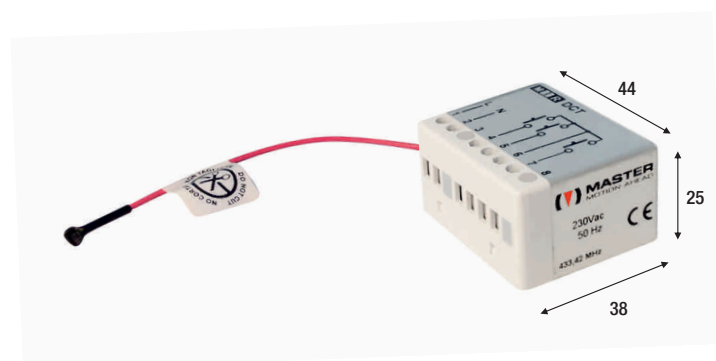
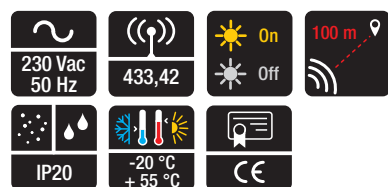

Quote espresse in "mm" - Dimensions expressed in "mm" - Medidas expresadas en "mm" - Dimensions exprimées en "mm" - Maße ausgedrückt in "mm"

SMART-Device Bluetooth

**5 YEAR WARRANTY**

# Btime

cod. BTH.000.001

GET IT ON Google Play



Master BTime



**UNITA' DI CONTROLLO BLUETOOTH**  
**BLUETOOTH CONTROL UNIT**  
**UNIDAD DE CONTROL BLUETOOTH**  
**DISPOSITIF DE CONTRÔLE BLUETOOTH**  
**BLUETOOTH-STEUEREINHEIT**

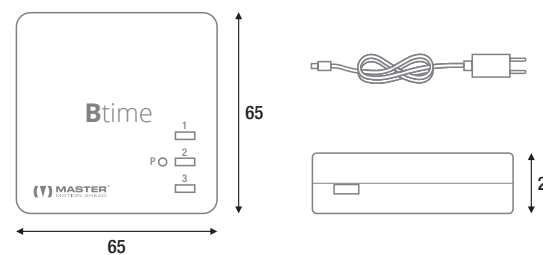

### ITALY CARATTERISTICHE GENERALI

- Dispone di memoria interna per timers, gruppi e scenari.
- Applicazione gratuita solo su sistema operativo Android.
- Necessita del trasmettitore radio memorizzato al prodotto da associare.
- Possibilità di fissaggio diretto a muro.
- Alimentatore con presa USB incluso nella confezione.

### ENGLISH GENERAL FEATURES

- Internal memory for saving timers, groups and scenarios.
- Free app available for Android OS.
- It requires a radio transmitter linked to the product to be connected.
- It's possible to hang the device on the wall.
- USB cable and power plug included.

### SPANISH CARACTERISTICAS GENERALES

- Memoria interna para almacenar temporizadores, grupos y escenarios.
- Aplicación gratuita y disponible para Android OS.
- Requiere del transmisor de radio memorizado en el producto que se debe asociar.
- Posibilidad de fijación directa a pared.
- Cable USB con clavija incluido.

### FRANCE CARACTÉRISTIQUES GÉNÉRALES

- Mémoire interne pour la sauvegarde de minuteurs, groupes et scénarios.
- Application gratuite et disponible pour Android OS.
- L'émetteur radio doit être mémorisé avec le produit à associer.
- Possible fixation au mur.
- Câble et prise d'alimentation USB inclus.

### GERMANY ALLGEMEINE MERKMALE

- Verfügt über internen Speicher für Timer, Gruppen und Szenarien.
- Kostenlose App, verfügbar nur für Android OS.
- Damit die Steuereinheit funktionieren kann, muss der Funksender mit dem zu paarenden Produkt gespeichert sein.
- Vorbereitet für die Wandinstallation.
- Netzteil mit USB-Buchse in der Packung enthalten.

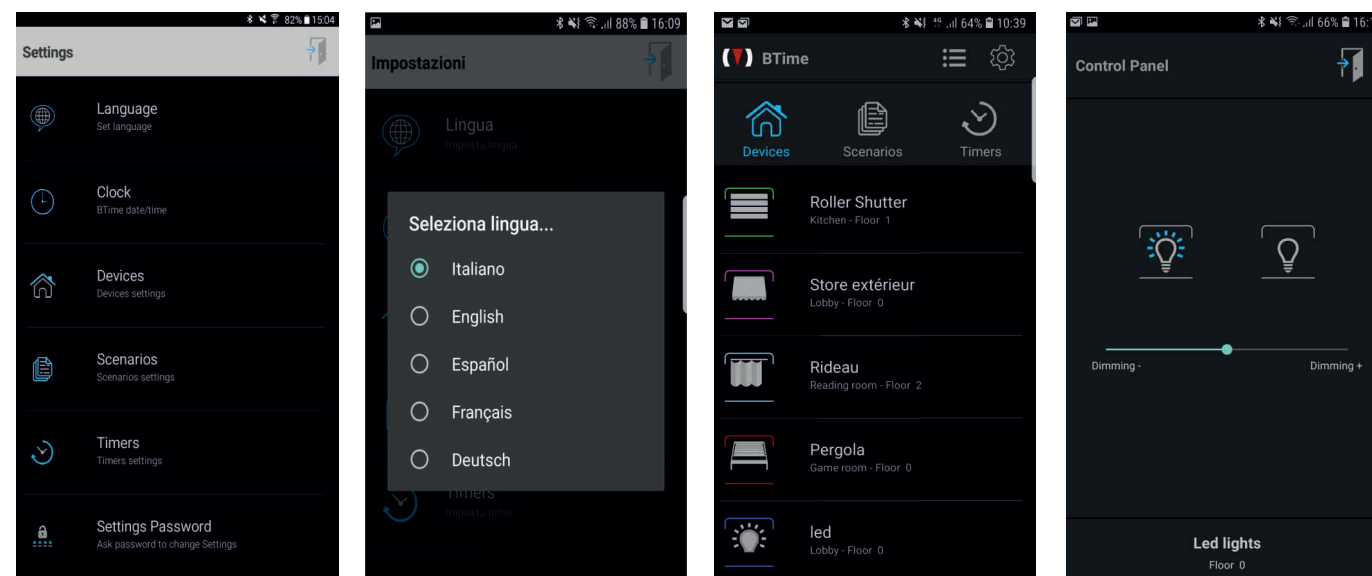

Quote espresse in "mm" - Dimensions expressed in "mm" - Medidas expresadas en "mm" - Dimensions exprimées en "mm" - Maße ausgedrückt in "mm"



SMART-Device



5 YEAR WARRANTY

# Bjob

cod. BTH.PRO.001



Master BJob



**UNITA' DI CONTROLLO BLUETOOTH PER INSTALLATORI**  
**BLUETOOTH CONTROL UNIT FOR TECHNICIANS**  
**UNIDAD DE CONTROL BLUETOOTH PARA INSTALADORES**  
**DISPOSITIF DE CONTRÔLE BLUETOOTH POUR PROFESSIONNELS**  
**BLUETOOTH-STEUEREINHEIT FÜR INSTALLATEURE**

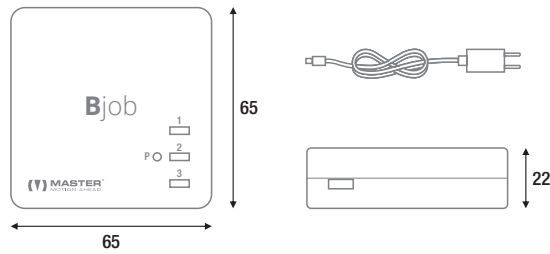

### ITALY CARATTERISTICHE GENERALI

- Dispositivo per assistenza tecnica.
- Applicazione gratuita solo su sistema operativo Android.
- Necessita del trasmettitore memorizzato al prodotto di intervento.
- Possibilità di fissaggio diretto a muro.
- Alimentatore con presa USB incluso nella confezione.

### ENGLISH GENERAL FEATURES

- Device for technical support.
- Free app available for Android OS.
- The control unit requires a transmitter linked to the product to be operated.
- It's possible to hang it on the wall.
- USB cable and power plug included.

### SPANISH CARACTERISTICAS GENERALES

- Dispositivo de asistencia técnica.
- Aplicación gratuita y disponible para Android OS.
- La unidad de control requiere del transmisor memorizado en el producto de intervención.
- Posibilidad de fijación directa a pared.
- Cable USB con clavija incluido.

### FRANCE CARACTÉRISTIQUES GÉNÉRALES

- Dispositif d'assistance technique.
- Application gratuite et disponible pour Android OS.
- Pour permettre à l'unité de commande de fonctionner, l'émetteur doit être mémorisé avec le produit d'intervention.
- Possible fixation au mur.
- Câble et prise d'alimentation USB inclus.

### GERMANY ALLGEMEINE MERKMALE

- Vorrichtung für den Kundendienst.
- Kostenlose App, verfügbar nur für Android OS.
- Damit die Steuereinheit funktionieren kann, muss der Sender mit dem Fernwartungsprodukt gespeichert sein.
- Vorbereitet für die Wandinstallation.
- Netzteil mit USB-Buchse in der Packung enthalten.

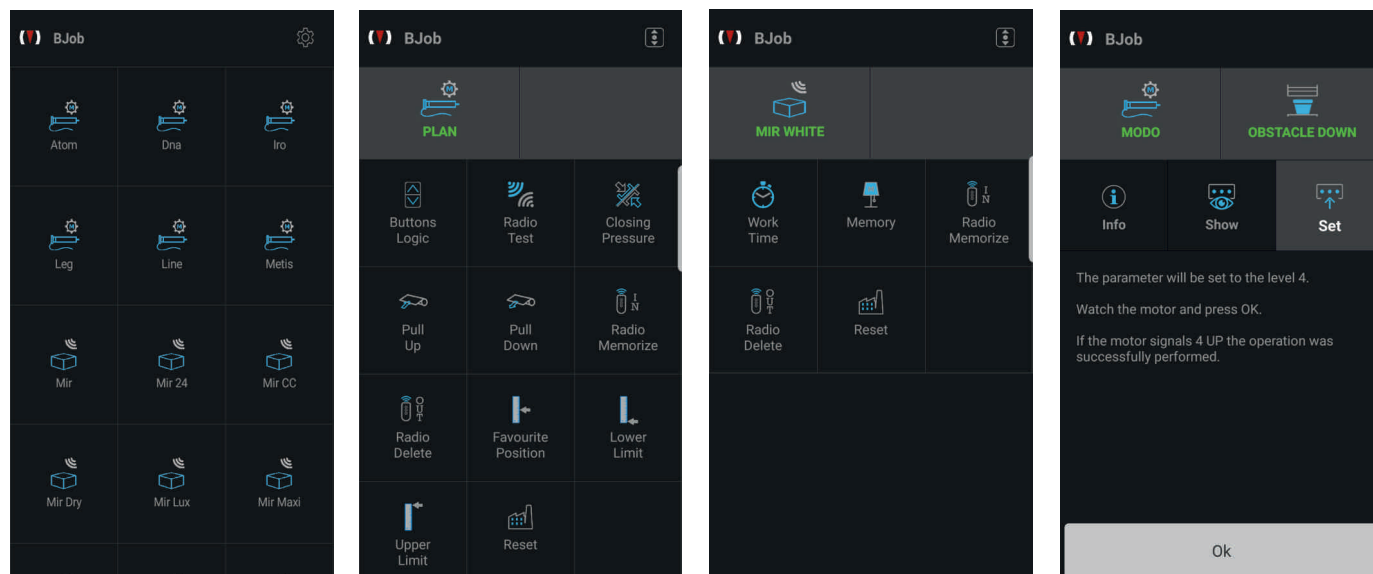

Quote espressa in "mm" - Dimensions expressed in "mm" - Medidas expresadas en "mm" - Dimensions exprimées en "mm" - Maße ausgedrückt in "mm"