



Instruction guide : compact wind device for 2 motors

WARNINGS

Dear Customer, thank you for purchasing a MASTER product.

Here you will find important information regarding the methods of use and the safety of installation. **Comply with the following information and keep for future reference.** WIND COMPACT DUO is a wind safety device, with high voltage controls, for awnings, screens or similars. This device rolls up the awning when the wind speed exceeds the setting threshold. It controls 2 motors with mechanical limit switch. **FOR A CORRECT INSTALLATION, IT IS RECOMMENDED TO READ THIS INSTRUCTION GUIDE.**

The producer cannot be consider responsible for any damages due to improper, wrong or unreasonable use.

FIXING SYSTEM

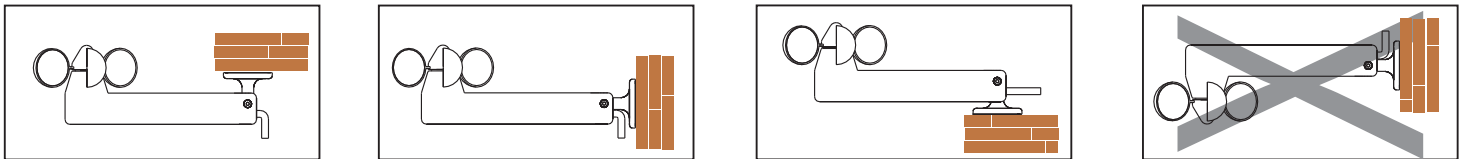

1. Technical and general features (related to 20°C working temperature)

Power Supply :	120-230 Vac 50/60 Hz	Wind threshold :	from 10 to 35 Km/h
Contacts capacity :	2 x 10 A@250 Vac	Consumption at rest :	< 1 W
Dimensions :	220 x 45 x 85 mm	Working temperature :	from -20°C to +55°C

2. Warnings on installation safety

01. The device must be installed by technical qualified staff so as to comply with the laws in force in your locality.
02. Check that the package is intact and it has not suffered damage in transit.
03. This device is subject to dangerous electrical voltage. **Carry out the connections without power supply.**
04. Always connect the ground wire (yellow/green).
05. **Adjusting the motor limit switch before connecting it to the device .**
06. The installer is forced to arrange an isolating device on the system (with 3 mm minimum opening contacts).
07. Do not modify, open or replace parts without manufacturer's permission.
08. For your safety, it is forbidden to work close the winding roller with motor supplied with power.
09. In case of malfunctioning do not keep on trying on the controls and warn the technician.
10. Operating on the device with caution, using suitable tools.
11. Check that the power supply line does not depend on circuit for lighting.
12. The device has not a section device, the technician will take care to provide it into the system.
13. Be sure that sensor has been installed on the correct position and well exposed to the wind and that there are no obstacles to the blades rotation.
14. Strictly adjusting the sensor with blades turned upside.
15. Use sensors produced by the same manufacturer, or the warranty will be cancelled.

3. Power Supply

The device can be supplied by 120-230 Vac voltage and 50/60 Hz frequency. The power supply must be applied to L and N terminals. Strictly keep to power supply phase (L) and neutral (N).

4. Manual controls

The manual controls can be permanent or momentary. If you use a permanent manual control and keep it in the lower position, on the coming out of the wind alarm mode, the device will put the awning back in the lower position. If you use a momentary manual control, on coming out of the wind alarm mode, the awning will stay in the raised position, so keeping the awning protected.

5. Wind Control

It closes the awning when the wind speed exceeds the set threshold for longer than 3 seconds.

It exits the wind alarm mode when about 8 minutes have elapsed since the last gust above the threshold. While in wind alarm mode, the manual controls are disabled.

Wind presence signal :

When the set wind threshold is exceeded, the red led switch on. If this condition continues for at least 3 seconds, the device gets into wind alarm mode and the red led flashes for the whole wind alarm time.

Forced exit from wind alarm mode :

Once device connected and wind alarm simulated (bring the awning to the middle position and rotate the sensor blades) it can be possible to exit from the alarm condition without waiting 8 minutes. Hold key «1» since red led (flashing during the alarm) switches off (about 5 seconds).

How to change wind threshold :

1. Bring the awning to middle position.
2. Hold key «1», since the awning moves upward.
3. The number of upward movements of the awning indicates the wind threshold currently set up.
4. If the threshold is the desired one, after about 8 seconds the awnings operate a number of upward movements and the device will exit from the setting.
5. If you want to change the currently set wind threshold, press and release key «1» the same number of times as the number of threshold you want, according to the table. After about 8 seconds the awning operates the same number of upward movements as the number of the threshold set up.

N.B.: in case of unsuccessful Wind threshold storage, repeat again the procedure.

factory settings

Motor movements number	Wind Threshold Value
1	10 Km/h
2	15 Km/h
3	20 Km/h
4	25 Km/h
5	30 Km/h
6	35 Km/h



6. Device Scheme

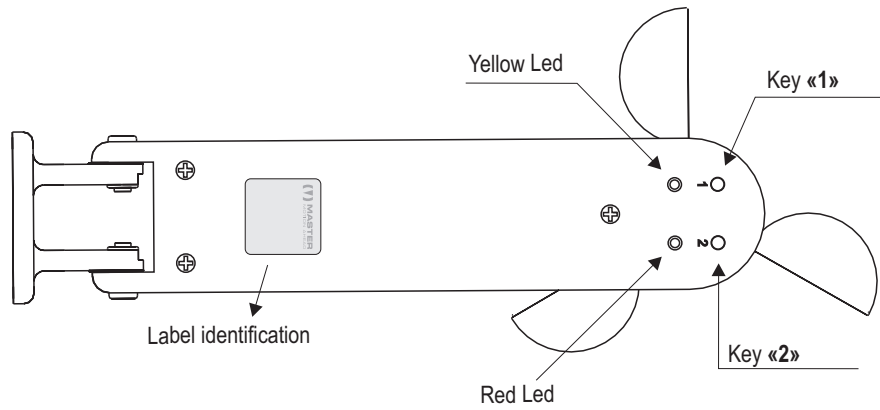

7. Electric Connection scheme

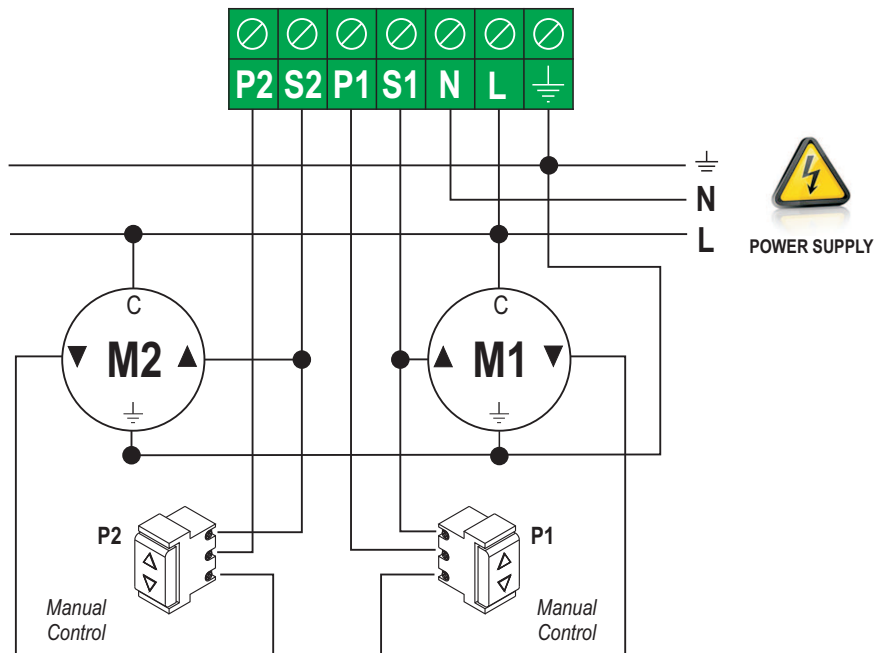

CHECK SYSTEM required

IN ORDER TO CHECK THAT CONNECTIONS HAVE BEEN CARRIED OUT AS THE SCHEME, BRING THE AWNING TO THE INTERMEDIATE POSITION AND ROTATE THE SENSOR BLADES SINCE WINDALARM SETS OFF.

THE AWNING MUST MOVE UPWARD. IF THE AWNINGS MOVE DOWNWARD REVERSE THE OPERATION WIRES OF MOTOR OR MOTORS. IT IS POSSIBLE TO EXIT FROM WIND ALARM WITHOUT WAITING 8 MINUTES, KEEP HOLD KEY «1» SINCE RED LED SWITCHES OFF.

8. Expired



At the end of the product cycle, dispose as provide by local regulation, or deliver again to the retailer when purchasing a new one. This product could contain polluting substance for the environment and dangerous for health, if expired in a wrong way.
For that it is forbidden to dispose the product with the domestic waste.