



## Instruction guide : wind rain control for 2 motors

### WARNINGS

Dear Customer, thank you for purchasing a MASTER product.

Here you will find important information regarding the methods of use and the safety of installation. **Comply with the following information and keep for future reference.** WIND DUO is a wind rain safety device for awnings, screens or similars. This device rolls up the awning when wind and rain speed exceeds the setting threshold. It controls 2 motors with mechanical limit switch.

**FOR A CORRECT INSTALLATION, IT IS RECOMMENDED TO READ THIS INSTRUCTION GUIDE.**

**The producer cannot be consider responsible for any damages due to improper, wrong or unreasonable use.**

### EXPIRED

At the end of the product cycle, dispose as provide by local regulation, or deliver again to the retailer when purchasing a new one. This product could contain polluting substance for the environment and dangerous for health, if expired in a wrong way.

### 1. Technical and general features (related to 20°C working temperature)

<b>Power Supply :</b>	230 Vac 50/60 Hz	<b>Sensor Supported :</b>	X15C sensor, X11 sensor
<b>Contacts capacity :</b>	2x10 A@250 Vac	<b>Protection Degree :</b>	Ip55
<b>Dimensions :</b>	100 x 100 x 60 mm	<b>Protective Fuse</b>	5x20 fast 6,3 Amp
<b>Wind threshold :</b>	from 7 to 40 Km/h	<b>Working temperature :</b>	from -20°C to +55°C

### 2. Warnings on installation safety

01. The device must be installed by technical qualified staff so as to comply with the laws in force in your locality.
02. Check that the package is intact and it has not suffered damage in transit.
03. This device is subject by dangerous electric voltage. **Make connections without power supply.**
04. Always connect the ground wire (yellow/green).
05. **Adjust the motor limit switch before connecting it to the device.**
06. Manual controls with high voltage, be careful.
07. The installer is forced to arrange a section device on the system (with 3 mm minimum opening contacts).
08. Do not change, open or replace parts without manufacturer's permission.
09. For your safety, it is forbidden to work close to the roller tube with motor supplied.
10. In case of malfunctioning do not keep on trying on control and warn the technician.
11. Operating on the device with caution, using suitable tools.
12. Check that the power supply line does not depend on circuit for lighting.
13. The device has not a section part, the technician will take care to provide it into the system.
14. Be sure that sensor has been installed on the correct position and well exposed to the wind and that there are no obstacles to the blades rotation.
15. Place rain sensor at about 30/40° slope (see sensor X11 manual).
16. Strictly adjusting the sensor with blades turned upside.
17. Using sensors produced by the same manufacturer, or the warranty will be cancelled.
18. The producer cannot be consider responsible for any damages due to improper, wrong or unreasonable use.

### 3. Manual control

The device is provided by two manual controls that can be permanent or momentary. Through this controls it is possible to move two awnings, manually or separately. Manual controls will be disabled in wind alarm condition.

### 4. Wind Rain control

It closes the awning when the wind or rain speed exceeds the set threshold for longer than 3 seconds.

It exits from wind or rain alarm mode after about 8 minutes . During the wind or rain alarm mode, the manual controls are disabled.

#### How to adjusting wind threshold :

rotating the trimmer on the device. Threshold is adjustable from 7 Km/h (trimmer completed rotate on the left) to 40 Km/h (trimmer completed rotate on the right).

The factory sets up the wind threshold at about 15 Km/h.

#### Wind presence signal :

When the set wind threshold is exceeded, the red led switches on. If this condition continues for at least 3 seconds, the device enters into wind alarm mode and red led flashes for the whole wind alarm time.

#### Forced exit from wind alarm mode :

Once the device connected and wind alarm simulated (bring the awning to middle position and rotate the sensor blades) it can be possible to exit from alarm condition without waiting 8 minutes.

Hold key RESET since led (flashing during the alarm) switches off (about 5 seconds).

To adjust X11 rain sensor refer to instruction guide of the sensor itself.

### 5. Fixing system

#### RIGHT FIXING

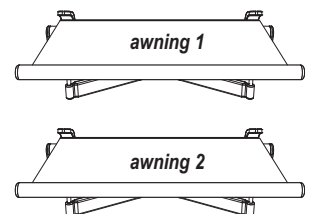
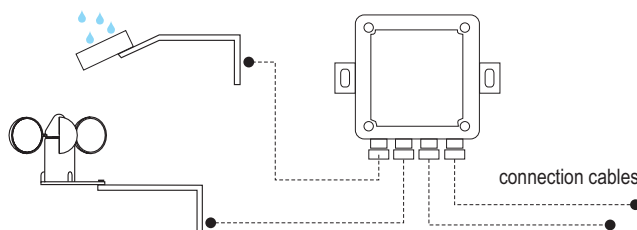
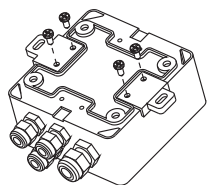

#### WRONG FIXING

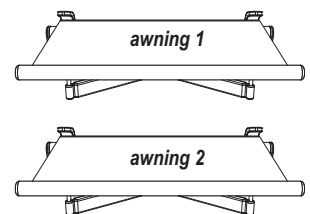
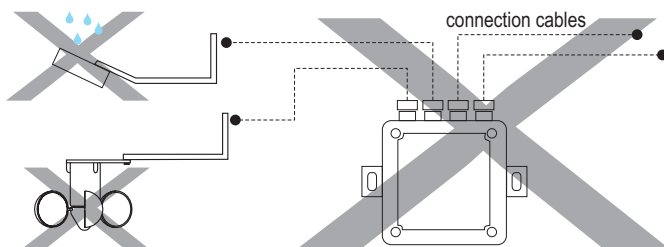

## 6. Device Scheme

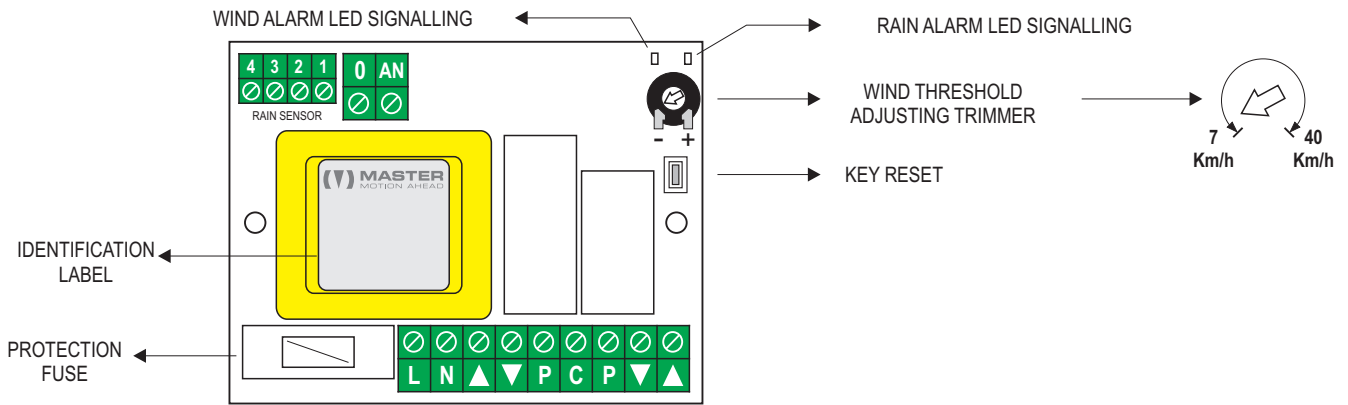

## 7. Electric Connection Scheme

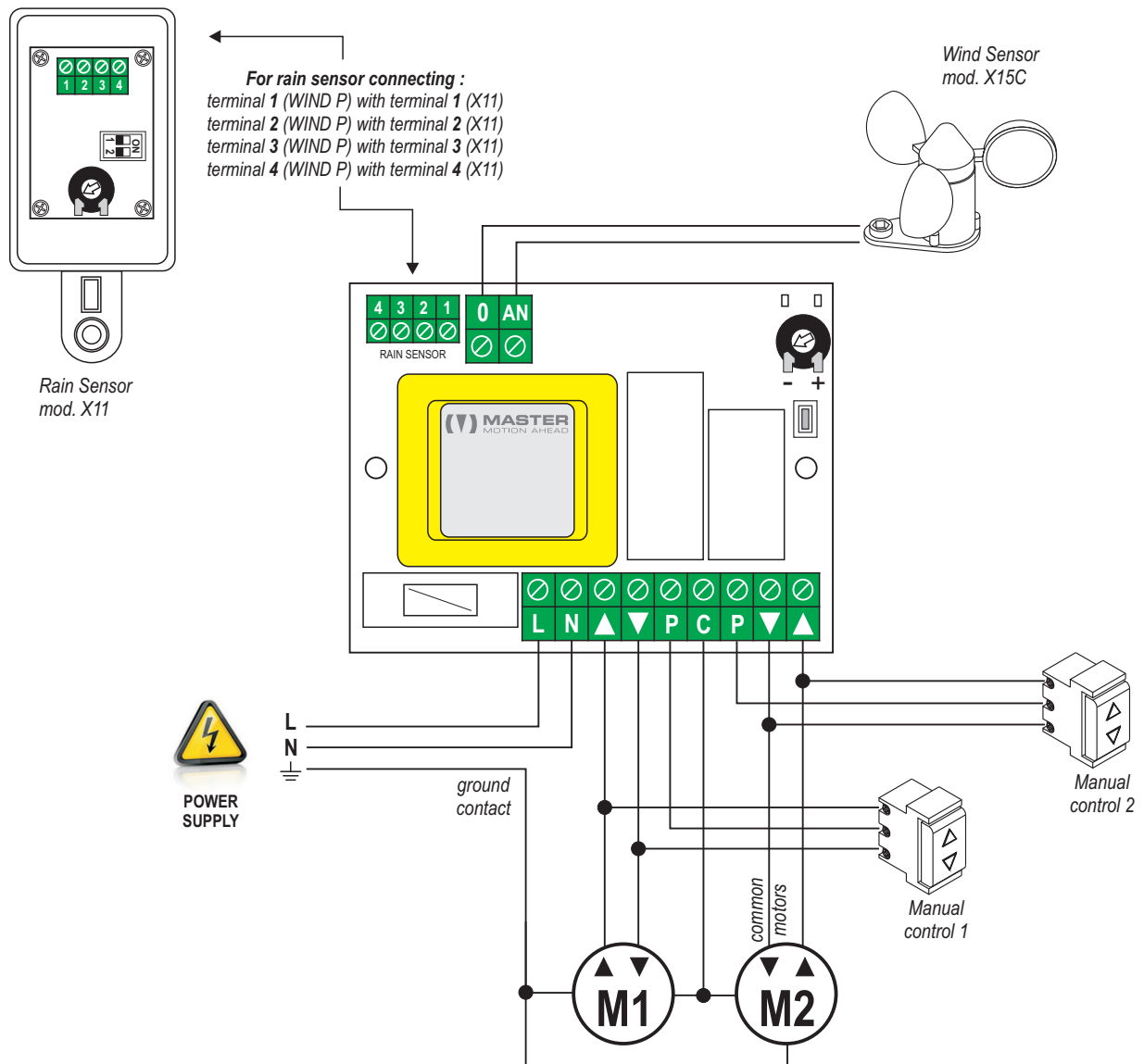

### SYSTEM CHECK required

IN ORDER TO CHECK THAT CONNECTIONS HAVE BEEN CARRIED OUT AS IN THE SCHEME, BRING THE AWNING TO THE INTERMEDIATE POSITION AND ROTATE THE SENSOR BLADES SINCE WIND ALARM BEGINS. THE AWNING MUST MOVE UPWARD. IF THE AWNING MOVES DOWNWARD REVERSE THE OPERATION WIRES OF MOTOR OR MOTORS.

IT IS POSSIBLE TO EXIT FROM WIND ALARM WITHOUT WAITING 8 MINUTES, KEEP HOLD KEY «RESET» SINCE RED LED SWITCHES OFF.